



KLIXON | 20413, 20600, and 20650 SERIES FIXED TEMPERATURE THERMOSTATS Snap-Action Automatic or Manual Reset

WORLD CLASS PERFORMANCE

The 20413, 20600 and 20650 series thermostats are especially designed for applications where space, capacity and ease of assembly are important production factors.

They are fixed-setting, snap acting, automatic or manual reset temperature controls ideal for applications such as: AC, Heating and Ventilation equipment, dryers, unit heaters, etc.

Sensata Technologies has been a leading global supplier of pressure sensors & switches for over 50 years.

Key Features

- Klixon snap-action bimetal disc assures positive make/break action.
- Available with surface, thru-wall, well or cavity-type mountings
- Temperature setting factory calibrated to your specifications
- High capacity – up to 30 amps at 120, 240, and 277 VAC resistive.
- Extra high capacity – up to 40 amps at 120 and 240 VAC resistive

Description

All automatic series are available as limit switches (open on temperature rise) or fan switches (close on temperature rise). Switch action is SPST, SPDT, or DPST with automatic reset types. Manual reset is available as a limit switch in SPST construction only.

The switch mechanism is actuated by the Klixon snap-action, bimetal disc which may be enclosed or exposed. Enclosed disc devices are particularly recommended for applications in which dust and lint are prevalent in the environment. Exposed disc types are used in applications where a faster thermal response to radiant heat is needed. Contact parts are enclosed for both disc types for protection against contamination.

Mountings and Terminals

A variety of terminals and mounting flanges are available to meet installation requirements of most applications.

Flanges can be used for surface or thru-wall mountings; or, thermostats can be supplied without flanges for well or cavity-type mountings. Flange rotations are specified by looking down on the terminals and rotating the flange 30°, 45°, or 90° CW or CCW.

Flanges Available

- Small oval bottom flange
- Integral surface flange
- No flange cup
- 3/4" deep cup
- Special oval bottom flange

Electrical connections to the thermostat must be tight; otherwise, resistance in a loose connection may cause sufficient temperature rise to affect the performance of the thermostat or damage the terminals or the lead wire insulation.

KLIXON[®] | 20413, 20600, and 20650 SERIES

FIXED TEMPERATURE THERMOSTATS

Snap-Action Automatic or Manual Reset

Terminals Available

Quick connects are available in brass, tin plated, or plain brass.

- 1/4" Quick connects 0°, 30°, 45°, 90° terminals are male spade type .250" x .032" thick.
- Brass screw terminals 0°, 45°
When screw terminals are specified, washer head screws are supplied unassembled. Assembled washer head screws are available at extra cost. Standard screw terminals have 8-32 NC-2 threads.

Temperature Settings, Tolerances and Nominal Differentials

The ranges of temperature settings, tolerances, and nominal differentials shown below are available. Differential is the difference between opening and closing temperature in °F. For example, a thermostat which opens at 180°F and closes at 140°F has a 40° differential. (Lowest unit prices are achieved by selecting differentials in the 30°F to 59°F range). For temperature settings and differentials other than those shown, please consult Marketing.

Standard Tolerances

Highest Temperature Setting °F	Nominal Differential °F	Standard Tolerances	
		Open °F	Close °F
-10 to 80	10 to 14*	±5	±5
	15 to 29	±6	±6
	30 to 59	±6	±7
	60 to 150	±7	±8
81 to 200	10 to 29*	±5	±5
	30 to 39	±5	±6
	40 to 59	±5	±7
	60 to 150	±6	±8
201 to 250	20 to 29	±5	±6
	30 to 39	±5	±7
	40 to 59	±6	±8
	60 to 150	±7	±9
251 to 300	30 to 39	±6	±8
	40 to 59	±7	±10
	60 to 150	±8	±11
	301 to 350 **	30 to 39	±7
40 to 59		±8	±12
60 to 150		±9	±13

- Available in SPST construction only. SPDT thermostats must have 15° minimum differentials.
- **20413 series – up to 300°
- 20600 series – up to 350°
- 20650 / 54 series – up to 300°; minimum differential 30°.

Manual Reset Constructions

There are two basic manual reset constructions:

- 1) Manual Override – contacts can be closed at any time after device has actuated by depressing reset button.
- 2) Trip-Free – contacts will remain open after device has actuated until bimetal disc resets, even if reset button is depressed.

Agency Recognition

Klixon 206 Series Thermostats are recognized by UL and CSA. Please consult Marketing for international approvals.

UL Electrical Group
File No. E9977
U.S. Guide No. XAPX2
Canada Guide NO. XAPX8
HC&R Group
File NO. MP986
U.S. Guide No. MBPR2
Canada Guide No. MBRR8

Automatic Reset Standard Constructions



Manual Reset Standard Constructions



KLIXON[®] | 20413, 20600, and 20650 SERIES

FIXED TEMPERATURE THERMOSTATS

Snap-Action Automatic or Manual Reset

Underwriters' Laboratories Electrical Current Ratings

Device	Contacts	Number Cycles	120 V				240 V				277 V				480 V				800 mV DC
			Amps Res	FLA	LRA	Pilot Duty	Amps Res	FLA	LRA	Pilot Duty	Amps Res	FLA	LRA	Pilot Duty	Amps Res	FLA	LRA	Pilot Duty	
20413 MR	1-3	6,000	48	16	96	480	48	8	48	690					48			690	
20613	1-3	6,000	48	16	96	480	48	8	48	690					48			690	
20600D	1-2	100,000	10	5.8	34.8	125	5	2.9	17.4	125									
	1-3	30,000	25	16	84	672	25	12	60	960	22	8	42	775					
	1-2	30,000	10	5.8	34.8	270	5	4.2	17.4	270	5			125					
20601F, L (appliance)	1-3	100,000	25	10	60	480	25	5	30	480									
	1-3	30,000	25	16	84	672	25	12	60	960	22	8	42	775	13	5	30		
20601 (HVAC)	1-3	100,000	16.6	16.6	88	480	8.3	8.3	49.8	690	7.2	7.2	43.2	1630					
20602F or L	1-3	100,000				125													X
20603/5	1-3	100,000	40	35	110	880	40	35	110	1760	35	30	95	1760	20	9	30	960	
20604F, L	1-3	100,000	25	10	60	480	25	5	30	380	22	8	42	775	13	5	10	320	
20606F, L	1-3	100,000				125													
20611L MR	1-3	6,000	25	10	60	480	25	5	30	480									
20612 MTR	1-3	6,000																	X
20616 MR	1-3	6,000				125													
20615L MRTF	1-3	6,000	16.6	10	60	480	8.3	5	30	480	7.2			690					
20619L MRTF	1-3	6,000	25	10	60	480	25	5	30	480	25			690					
20650F, L	1-3, 4-5	100,000	25	10	60	480	25	5	30	480	22	8	42	775					
20650F, L, H	1-3	30,000	25	10	60	480	25	5	30	480	23	23	100	1855	13	5	30	400	
	4-5	30,000	25	16	84	672	25	12	60	960	23	23	88	1633					
20650H	1-3	6,000					25	7	42	670									
	4-5	6,000					23	7	42	670									
	5-2	6,000					5	5.8	39.8	556									

Standard Configurations

Model	Switch Type	Capacity	Contacts	Clearance	
				Thru Air	Over Surface
20413L	MR-TF	High	Ag	3/8"	1/2"
20600D	SPDT	High	Ag	1/8"	1/4"
20601L, F	SPST	High	Ag	1/8"	1/4"
20602L, F	SPST	mVdc	Au	1/8"	1/4"
20603L, F	SPST	Extra High	AgCdO	1/8"	1/4"
20604L, F	SPST	High	Ag	1/4"	3/8"
20605L, F	SPST	Extra High	AgCdO	1/4"	3/8"
20606L, F	SPST	Pilot Duty	Ag Ribbed	1/8"	1/4"
20611L	MR	High	Ag	1/8"	1/4"
20612L	MR	mVdc	Au	1/8"	1/4"
20615L	MR-TF	High	Ag	1/8"	1/4"
20616L	MR	Pilot Duty	Ag Ribbed	1/8"	1/4"
20619L	MR-TF	High	Ag	1/4"	3/8"
20650L, F	DPST	High	Ag	1/8"	1/4"

KLIXON® | 20413, 20600, and 20650 SERIES

FIXED TEMPERATURE THERMOSTATS

Snap-Action Automatic or Manual Reset

20413 Series Standard Constructions

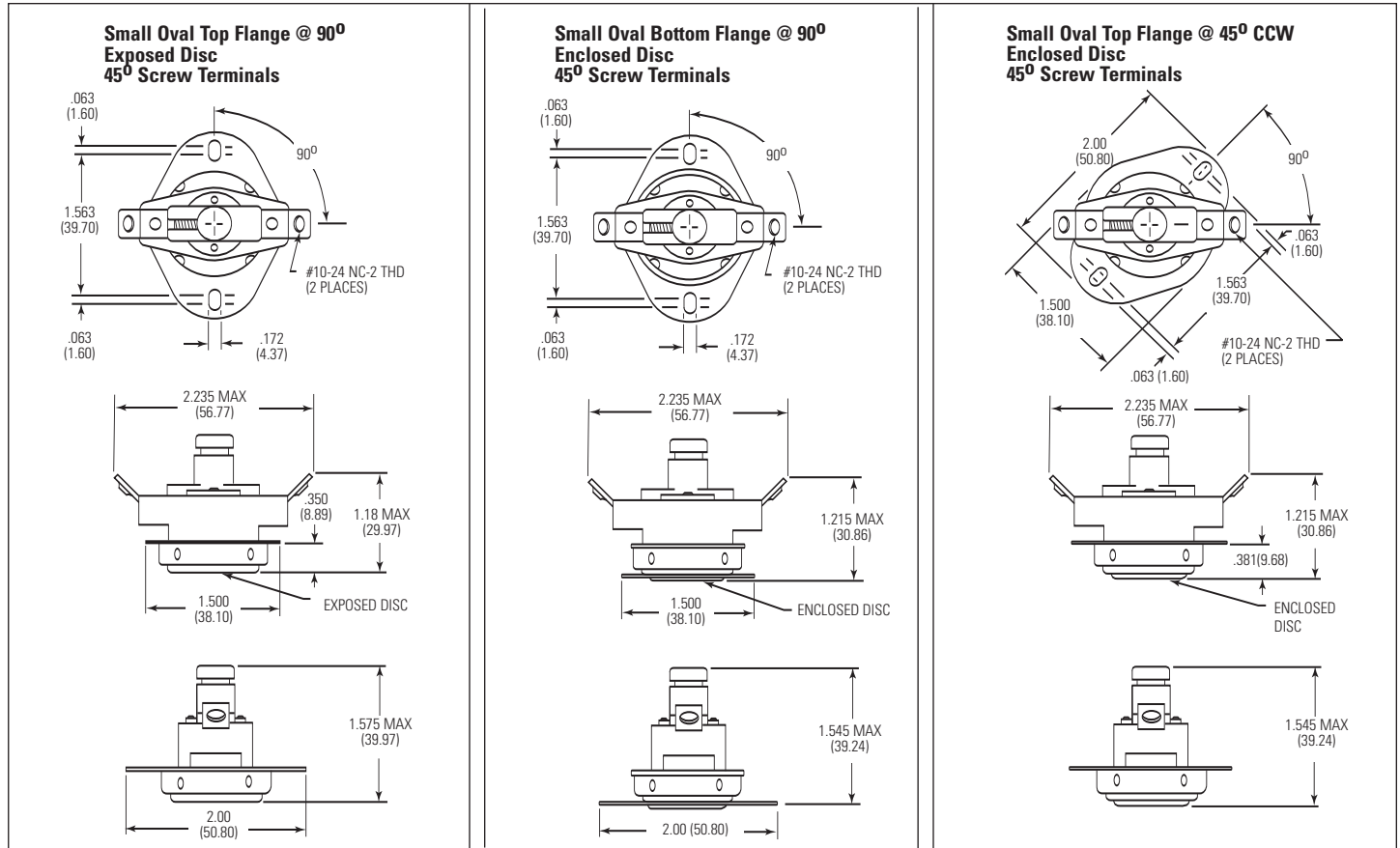

20650 Series Standard Constructions

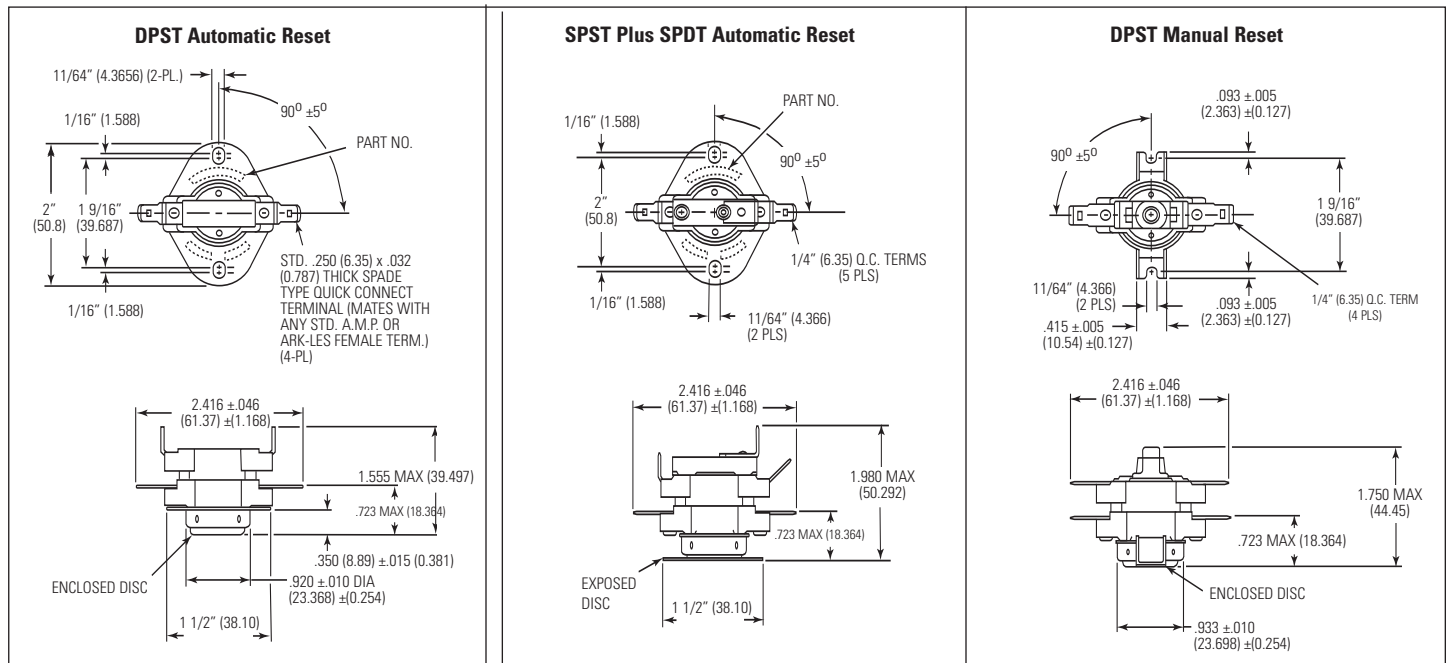

20600 Series Preferred Physical Construction

20601 / 04 / 06 F or L Small Oval Top Flange at 90° 1/4" Quick Connect Terminals

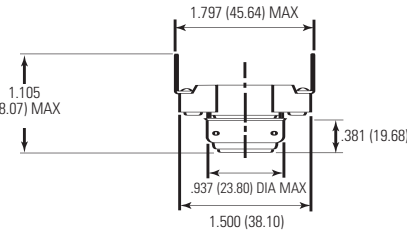
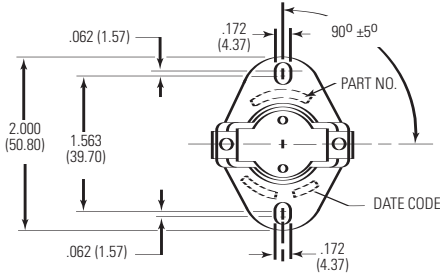

Exposed Disc

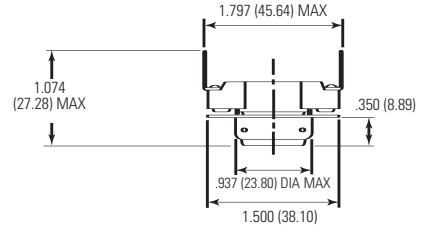

Enclosed Disc

Other Physical Constructions

20601 / 04 No Flange Cup, Thru-Wall Mounting Forked Terminals

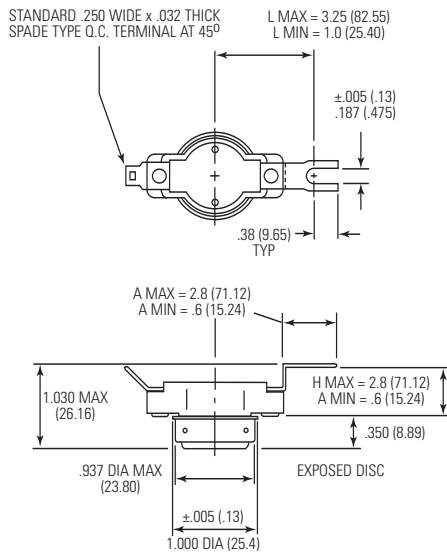

20600D Single-Pole, Double-Throw, Small Oval Top Flange at 90° Rotation Quick-Connect Terminals

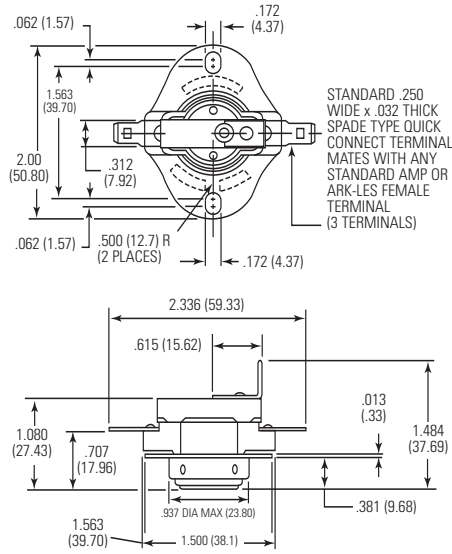

20601 / 04 / 06 Small Oval Bottom Flange at 90° Rotation Quick-Connect Terminals

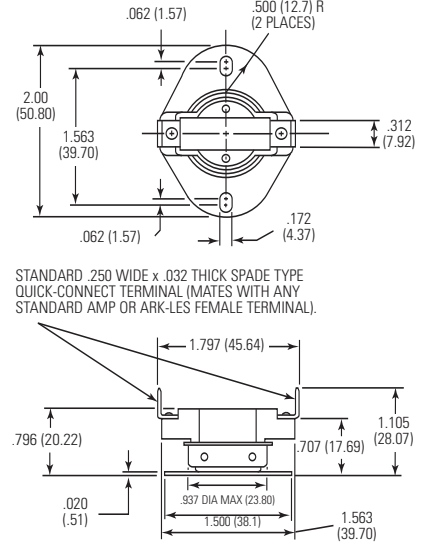

20601 / 04 Small Oval Flange, 3/4" Depth Cup Quick-Connect Terminals

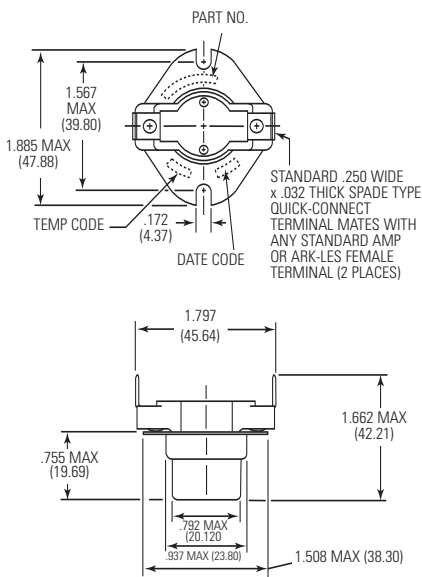

20611 / 20616 / L Manual Reset, Manual Override Integral Flange, Surface Mounting Quick-Connect Terminals

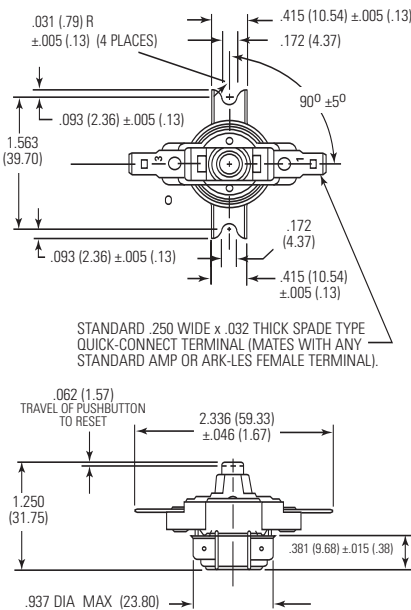

20615L / 20619L Special Oval Bottom Flange Manual Reset, Trip Free, Surface Mounting 45° Screw Terminals

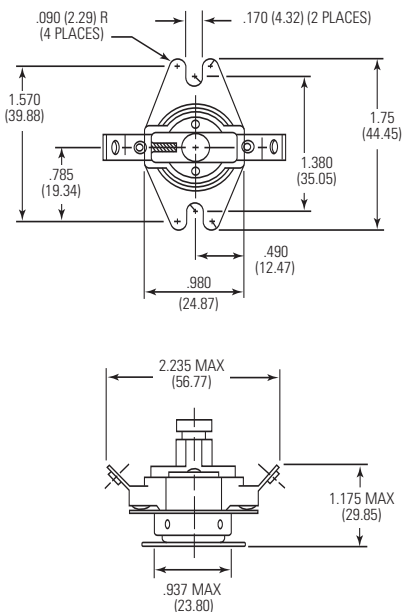

To facilitate processing your request, please fax this page to our Product Specialists.

To: Marketing Dept.
Sensata Technologies
Attleboro, MA 02703

Phone: (508) 236-1894
(508) 236-3192
Fax: (508) 236-2349

From _____
Company _____
Address _____
Phone _____
Fax _____

The following information will help us determine the correct thermostat design for your application. You may refer to the charts on pages 2 and 3 for assistance.

Request: Pricing _____ Application Assistance _____

Description of Application _____

Estimated Annual Usage _____

Automatic Reset _____ MR _____ MR-TF _____ SPST _____ SPDT _____ DPST _____

Open Temperature _____ Maximum Tolerance _____

Close Temperature _____ Maximum Tolerance _____

Temperature Exposures: Maximum _____ Minimum _____

Location With Respect to Heat Source _____

Temperature Transfer Medium (air, metal surface, etc.) _____

Type of Heat Source: Convection _____ Conduction _____ Radiation _____

Electrical Requirements: _____ Amps @ _____ Volts; AC or DC _____

Resistive _____ Inductive _____ * Capacitive _____ *

Tungsten Filament _____ Milliamp _____ Pilot Duty _____

*If inductive or capacitive, indicate power factor _____

(If available, please send copy of electrical / plumbing diagram).

Switch Termination (type and angle) _____

Flange (type and angle of rotation) _____

Enclosed or Exposed Disc _____

Environment (dust, lint, chemical fumes, etc.) _____

Agency Approvals _____



Sensata Technologies

529 Pleasant Street, MS B19
Attleboro, Massachusetts 02703-0964
Phone: 1-888-438-2214
1-508-236-1894
Fax: (508) 236-2349
email: sensata@sensata.com

www.sensata.com

Important Notice: Sensata Technologies (Sensata) reserves the right to make changes to or discontinue any product or service identified in this publication without notice. Sensata advises its customers to obtain the latest version of the relevant information to verify, before placing any orders, that the information being relied upon is current. Sensata assumes no responsibility for infringement of patents or rights of others based on Sensata applications assistance or product specifications since Sensata does not possess full access concerning the use or application of customers' products. Sensata also assumes no responsibility for customers' product designs.